



Doc. No. 78-4529-01

Installing the Cisco RPS Adapter Plate in Cisco 4000 Series Routers

Product Number: ACS-4000RPS=

This document describes how to install an adapter plate in Cisco 4000 series routers for use with the Cisco Redundant Power System (RPS). The Cisco RPS provides power system redundancy to external devices (such as routers, switches, or hubs). The system includes two fully redundant AC input power modules and four DC output power modules for connection to external devices. The Cisco RPS supports quasi-redundant and fully redundant power source configurations. To use the Cisco RPS with Cisco 4000 series routers, you must remove the existing power supply and replace it with a Cisco RPS adapter plate.

This document includes the following sections:

- Safety Recommendations, page 1
- Required Tools and Equipment, page 5
- Installing the Cisco RPS Adapter Plate in Cisco 4000 Series Routers, page 5
- Cisco Connection Online, page 14

Safety Recommendations

Follow these guidelines to ensure general safety:

- Keep the chassis area clear and dust-free during and after installation.
- Put the removed chassis cover in a safe place.
- Keep tools away from walk areas where you or others could fall over them.
- Do not wear loose clothing that could get caught in the chassis. Fasten your tie or scarf and roll up your sleeves.
- Wear safety glasses when working under any conditions that might be hazardous to your eyes.

Corporate Headquarters

Cisco Systems, Inc.
170 West Tasman Drive
San Jose, CA 95134-1706
USA

Copyright © 1997
Cisco Systems, Inc.
All rights reserved.

- Do not perform any action that creates a potential hazard to people or makes the equipment unsafe.

Safety Warnings

Safety warnings appear throughout this publication in procedures that, if performed incorrectly, may harm you. A warning symbol precedes each safety warning.



Warning This warning symbol means *danger*. You are in a situation that could cause bodily injury. Before you work on any equipment, be aware of the hazards involved with electrical circuitry and be familiar with standard practices for preventing accidents. To see translations of the warnings that appear in this publication, refer to the *Regulatory Compliance and Safety Information* document that accompanied this device.

Waarschuwing Dit waarschuwingssymbool betekent gevaar. U verkeert in een situatie die lichamelijk letsel kan veroorzaken. Voordat u aan enige apparatuur gaat werken, dient u zich bewust te zijn van de bij elektrische schakelingen betrokken risico's en dient u op de hoogte te zijn van standaard maatregelen om ongelukken te voorkomen. Voor vertalingen van de waarschuwingen die in deze publicatie verschijnen, kunt u het document *Regulatory Compliance and Safety Information* (Informatie over naleving van veiligheids- en andere voorschriften) raadplegen dat bij dit toestel is ingesloten.

Varoitus Tämä varoitusmerkki merkitsee vaaraa. Olet tilanteessa, joka voi johtaa ruumiinvammaan. Ennen kuin työskentelet minkään laitteiston parissa, ota selvää sähkökytkentöihin liittyvistä vaaroista ja tavanomaisista onnettomuuksien ehkäisykeinoista. Tässä julkaisussa esiintyvien varoitusten käännökset löydät laitteen mukana olevasta *Regulatory Compliance and Safety Information* -kirjasesta (määräysten noudattaminen ja tietoa turvallisuudesta).

Attention Ce symbole d'avertissement indique un danger. Vous vous trouvez dans une situation pouvant causer des blessures ou des dommages corporels. Avant de travailler sur un équipement, soyez conscient des dangers posés par les circuits électriques et familiarisez-vous avec les procédures couramment utilisées pour éviter les accidents. Pour prendre connaissance des traductions d'avertissements figurant dans cette publication, consultez le document *Regulatory Compliance and Safety Information* (Conformité aux règlements et consignes de sécurité) qui accompagne cet appareil.

Warnung Dieses Warnsymbol bedeutet Gefahr. Sie befinden sich in einer Situation, die zu einer Körperverletzung führen könnte. Bevor Sie mit der Arbeit an irgendeinem Gerät beginnen, seien Sie sich der mit elektrischen Stromkreisen verbundenen Gefahren und der Standardpraktiken zur Vermeidung von Unfällen bewußt. Übersetzungen der in dieser Veröffentlichung enthaltenen Warnhinweise finden Sie im Dokument *Regulatory Compliance and Safety Information* (Informationen zu behördlichen Vorschriften und Sicherheit), das zusammen mit diesem Gerät geliefert wurde.

Avvertenza Questo simbolo di avvertenza indica un pericolo. La situazione potrebbe causare infortuni alle persone. Prima di lavorare su qualsiasi apparecchiatura, occorre conoscere i pericoli relativi ai circuiti elettrici ed essere al corrente delle pratiche standard per la prevenzione di incidenti. La traduzione delle avvertenze riportate in questa pubblicazione si trova nel documento *Regulatory Compliance and Safety Information* (Conformità alle norme e informazioni sulla sicurezza) che accompagna questo dispositivo.

Advarsel Dette varselsymbolet betyr fare. Du befinner deg i en situasjon som kan føre til personskade. Før du utfører arbeid på utstyr, må du være oppmerksom på de faremomentene som elektriske kretser innebærer, samt gjøre deg kjent med vanlig praksis når det gjelder å unngå ulykker. Hvis du vil se oversettelser av de advarslene som finnes i denne publikasjonen, kan du se i dokumentet *Regulatory Compliance and Safety Information* (Overholdelse av forskrifter og sikkerhetsinformasjon) som ble levert med denne enheten.

Aviso Este símbolo de aviso indica perigo. Encontra-se numa situação que lhe poderá causar danos físicos. Antes de começar a trabalhar com qualquer equipamento, familiarize-se com os perigos relacionados com circuitos eléctricos, e com quaisquer práticas comuns que possam prevenir possíveis acidentes. Para ver as traduções dos avisos que constam desta publicação, consulte o documento *Regulatory Compliance and Safety Information* (Informação de Segurança e Disposições Reguladoras) que acompanha este dispositivo.

¡Advertencia! Este símbolo de aviso significa peligro. Existe riesgo para su integridad física. Antes de manipular cualquier equipo, considerar los riesgos que entraña la corriente eléctrica y familiarizarse con los procedimientos estándar de prevención de accidentes. Para ver una traducción de las advertencias que aparecen en esta publicación, consultar el documento titulado *Regulatory Compliance and Safety Information* (Información sobre seguridad y conformidad con las disposiciones reglamentarias) que se acompaña con este dispositivo.

Warning! Denna varningssymbol signalerar fara. Du befinner dig i en situation som kan leda till personskada. Innan du utför arbete på någon utrustning måste du vara medveten om farorna med elkretsar och känna till vanligt förfarande för att förebygga skador. Se förklaringar av de varningar som förekommer i denna publikation i dokumentet *Regulatory Compliance and Safety Information* (Efterrättelse av föreskrifter och säkerhetsinformation), vilket medföljer denna anordning.

Safety with Electricity

Follow these guidelines when working on equipment powered by electricity:

- Locate the emergency power-OFF switch in the room in which you are working. Then, if an electrical accident occurs, you can quickly shut the power OFF.



Warning Read the installation instructions before you connect the system to its power source.



Warning Ultimate disposal of this product should be handled according to all national laws and regulations.



Warning Only trained and qualified personnel should be allowed to install or replace this equipment.



Warning Before working on a chassis or working near power supplies, unplug the power cord on AC units; disconnect the power at the circuit breaker on DC units.

- Disconnect all power before doing the following:
 - Installing or removing a chassis
 - Working near power supplies



Warning Before working on equipment that is connected to power lines, remove jewelry (including rings, necklaces, and watches). Metal objects will heat up when connected to power and ground and can cause serious burns or weld the metal object to the terminals.

- Do not work alone if potentially hazardous conditions exist.

- Never assume that power is disconnected from a circuit. Always check.
- Look carefully for possible hazards in your work area, such as moist floors, ungrounded power extension cables, and missing safety grounds.
- If an electrical accident occurs, proceed as follows:
 - Use caution; do not become a victim yourself.
 - Turn OFF power to the system.
 - If possible, send another person to get medical aid. Otherwise, determine the condition of the victim and then call for help.
 - Determine if the person needs rescue breathing or external cardiac compressions; then take appropriate action.



Caution Use the Cisco RPS (model PWR600-AC-RPS) only to power the external device.

Seul le système d'alimentation redondant Cisco (RPS modèle PWR600-AC-RPS) doit servir à alimenter le dispositif externe.

Das externe Gerät darf nur mit einer redundanten Stromversorgung von Cisco, Modell PWR600-AC-RPS, betrieben werden.

外付部品の電源には、必ず Cisco RPS (モデル番号 PWR600-AC-RPS-CAB/PWR600-AC-RPS-NCAB) をご使用ください。

Para alimentar el dispositivo externo, usar exclusivamente el sistema de alimentación redundante (redundant power system = RPS) Cisco, modelo PWR600-AC-RPS.

Preventing Electrostatic Discharge Damage

Electrostatic discharge (ESD) can damage equipment and impair electrical circuitry. It occurs when electronic printed circuit cards are improperly handled and can result in complete or intermittent failures. Always follow ESD prevention procedures when removing and replacing cards. Ensure that the chassis is electrically connected to earth ground. Wear an ESD-preventive wrist strap, ensuring that it makes good skin contact. Connect the clip to an unpainted surface of the chassis frame to safely channel unwanted ESD voltages to ground. To properly guard against ESD damage and shocks, the wrist strap and cord must operate effectively. If no wrist strap is available, ground yourself by touching the metal part of the chassis.



Caution For safety, periodically check the resistance value of the antistatic strap, which should be between 1 and 10 megohms (Mohm).

Required Tools and Equipment

This kit includes the following items:

- Cisco RPS adapter plate, shown in Figure 1
- DC power rating label
- Warning label

Figure 1 Cisco RPS Adapter Plate for Cisco 4000 Series Routers

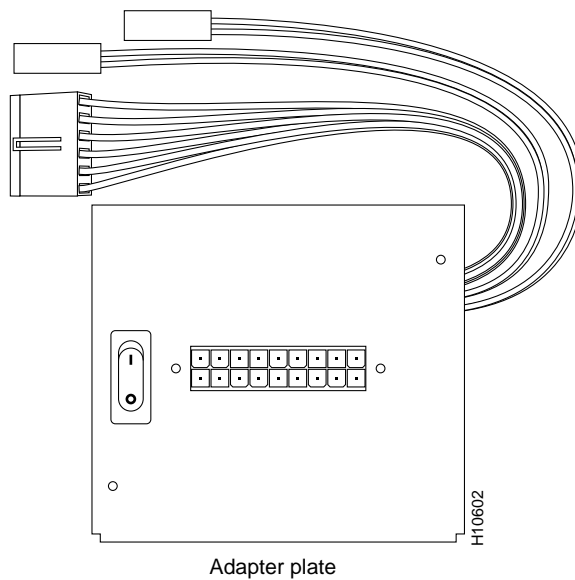

To install the adapter plate, you will also need the following tools and equipment (which are not included):

- Cisco 4000 series router
- Medium-size Phillips screwdriver
- ESD-preventive wrist strap
- Tie-wraps (optional)
- Antistatic bag (optional)

Installing the Cisco RPS Adapter Plate in Cisco 4000 Series Routers

To install the Cisco RPS adapter plate in Cisco 4000 series routers, perform the following procedures, which are described in this section:

- Remove the component tray
- Remove the power supply
- Install the Cisco RPS adapter plate
- Replace the component tray

Removing the Component Tray

Some Cisco 4000 series routers have a safety latch tab on the chassis that affects removing the component tray. (See Figure 2 and Figure 3.)

If you have a chassis with a safety latch tab, follow the procedure in the following section “Removing the Component Tray from a Chassis with a Safety Latch.”

If you have a chassis without a safety latch tab, follow the procedure in the section “Removing the Component Tray from a Chassis without a Safety Latch” later in this document.

Removing the Component Tray from a Chassis with a Safety Latch



Warning Do not touch the power supply when the power cord is connected. For systems with a power switch, line voltages are present within the power supply even when the power switch is OFF and the power cord is connected. For systems without a power switch, line voltages are present within the power supply when the power cord is connected.



Warning Before performing any of the following procedures, ensure that power is removed from the DC circuit. To ensure that all power is OFF, locate the circuit breaker on the panel board that services the DC circuit, switch the circuit breaker to the OFF position, and tape the switch handle of the circuit breaker in the OFF position.

Follow these steps to remove the component tray from a chassis with a safety latch.

- Step 1** Power OFF the system.
- Step 2** Attach your ESD-preventive wrist strap.
- Step 3** Disconnect all cables from the rear panel of the router.



Warning Before opening the chassis, disconnect the telephone-network cables to avoid contact with telephone-network voltages.



Warning Do not work on the system or connect or disconnect cables during periods of lightning activity.

- Step 4** Loosen the (nonremovable) screw on the back of the chassis, labeled “Chassis release screw” in Figure 2.
- Step 5** Slide the component tray out of the chassis shell while facing the chassis rear panel, pulling the handle on the right side of the chassis until the safety latch catches. (See Figure 2.)



Warning Before releasing the safety latch, support the component tray from underneath, either on your work surface or with your hands, to prevent personal injury. (See Figure 2.)

- Step 6** While supporting the component tray with one hand, push down on the safety latch tab while pulling out on the component tray.
- Step 7** Set the component tray on your work surface.

Figure 2 Removing the Component Tray from a Cisco 4000 Series Router With a Safety Latch

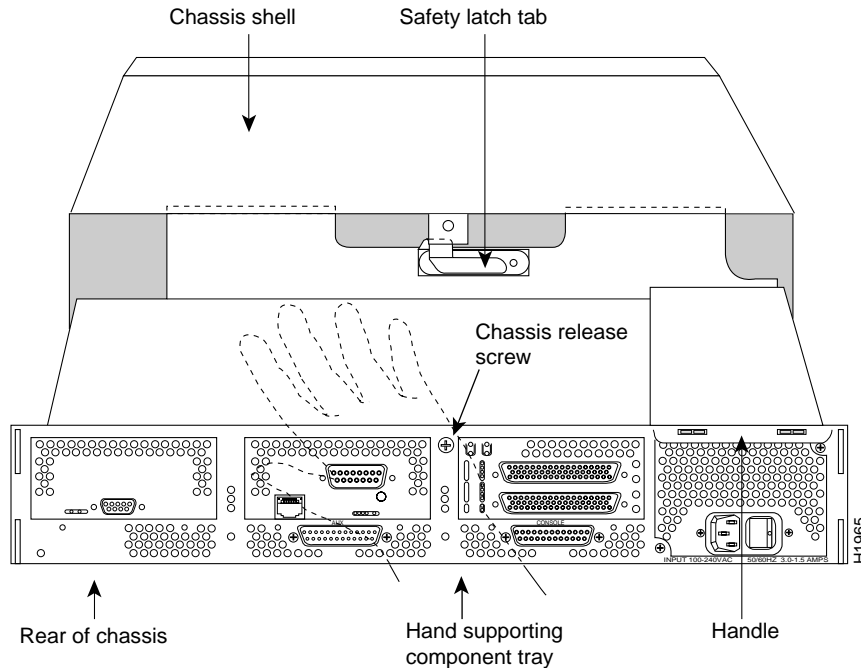

Removing the Component Tray from a Chassis without a Safety Latch



Warning Do not touch the power supply when the power cord is connected. For systems with a power switch, line voltages are present within the power supply even when the power switch is OFF and the power cord is connected. For systems without a power switch, line voltages are present within the power supply when the power cord is connected.



Warning Before performing any of the following procedures, ensure that power is removed from the DC circuit. To ensure that all power is OFF, locate the circuit breaker on the panel board that services the DC circuit, switch the circuit breaker to the OFF position, and tape the switch handle of the circuit breaker in the OFF position.

Follow these steps to remove the component tray from a chassis without a safety latch:

- Step 1** Power OFF the router.
- Step 2** Attach your ESD-preventive wrist strap.
- Step 3** Disconnect all cables from the rear panel of the router.



Warning Before opening the chassis, disconnect the telephone-network cables to avoid contact with telephone-network voltages.



Warning Do not work on the system or connect or disconnect cables during periods of lightning activity.

Step 4 Loosen the (nonremovable) screw on the back of the router chassis, labeled “Chassis release screw” in Figure 3.

Step 5 While facing the chassis rear panel, pull the handle on the right side of the router while supporting the component tray with one hand. Slide the component tray out of the chassis shell.



Warning Support the component tray from underneath, either on your work surface or with your hands, to prevent it from falling. (See the hand in Figure 3.)

Step 6 Set the component tray on your work surface.

Figure 3 Removing the Component Tray from a Cisco 4000 Series Router Without a Safety Latch

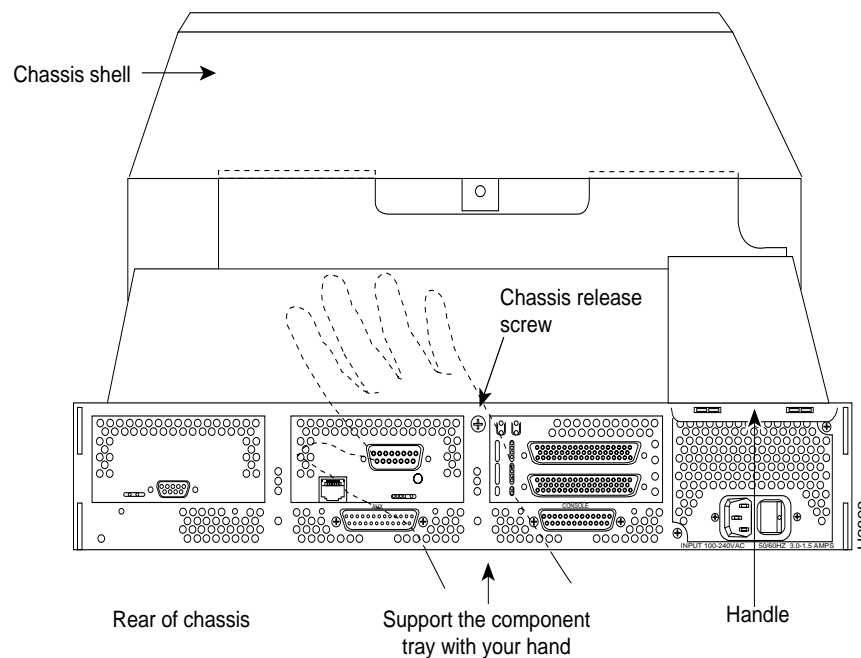

Removing the Power Supply

After you remove the component tray from the chassis shell, remove the internal power supply from the chassis. Although the AC power supply is shown in the illustrations that follow, the procedure is the same for removing both the AC and DC power supplies.

Take these steps to remove a power supply:

- Step 1** Locate the eight-pin connector on the system board near the front of the router. Squeeze the sides of the eight-pin connector and lift it away from the system board. (See Figure 4.)

Figure 4 Disconnecting the Cisco 4000 Series Eight-Pin Connector

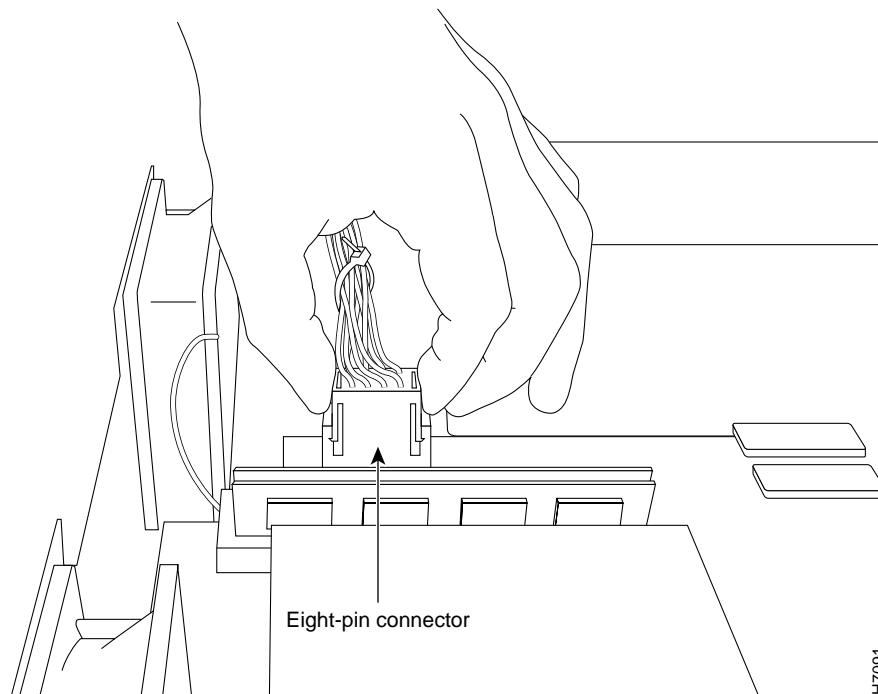

- Step 2** Locate the two small two-pin connectors used to power the fans. Grasp the two halves of the connector firmly and pull them apart. (See Figure 5.)

Note The number and placement of the cable tie-wraps in your router may differ from the illustration. If the cable tie-wraps on the harness interfere with removing the connectors, cut the tie-wraps, being careful not to cut the power cables.

Figure 5 Disconnecting the Cisco 4000 Series Two-Pin Connectors

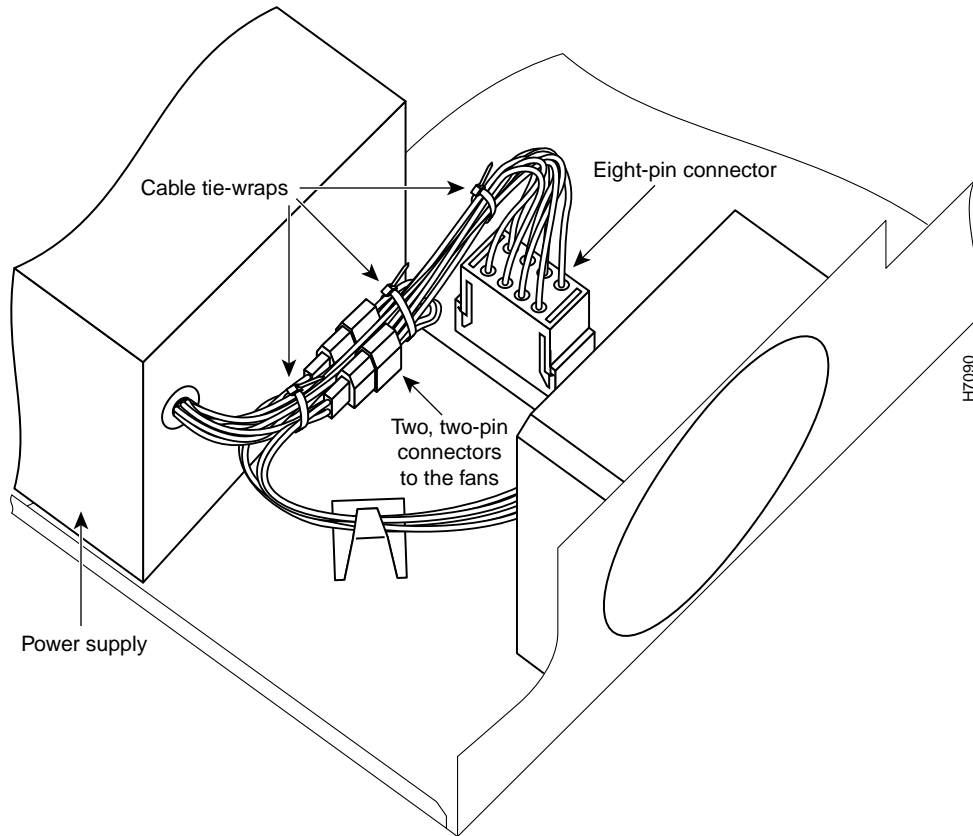

- Step 3** Remove the two external rear mounting screws and set them aside. (See Figure 6.)
- Step 4** Slide the power supply forward slightly in the chassis. (See Figure 7.) This disengages the built-in hooks that help secure the power supply to the chassis.
- Step 5** Lift the power supply out of the chassis.

Figure 6 Removing the Cisco 4000 Series Mounting Screws

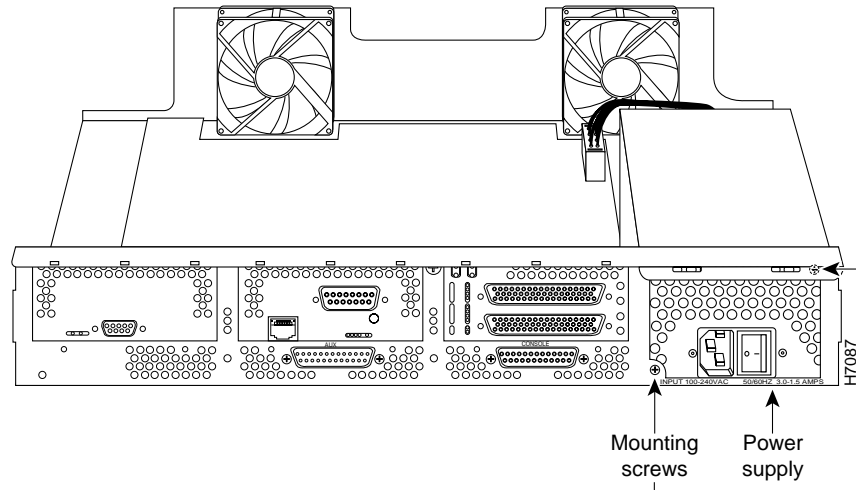
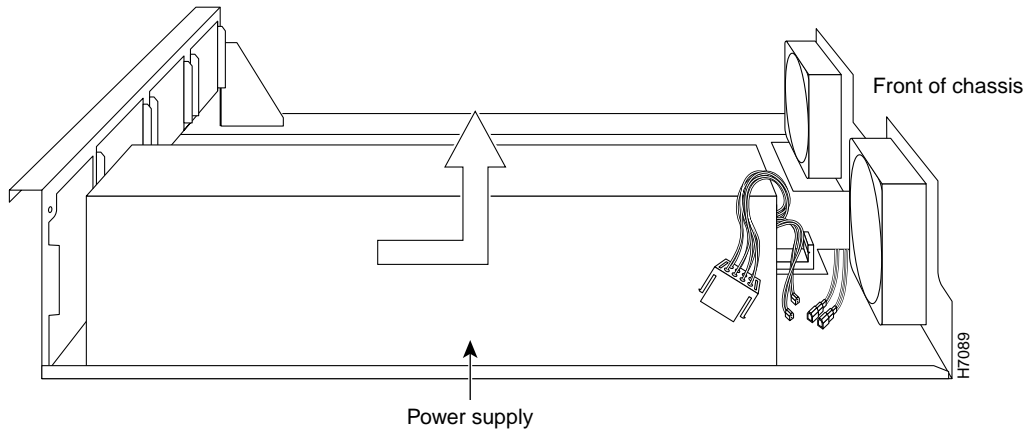

Figure 7 Removing the Cisco 4000 Series Power Supply



Installing the Cisco RPS Adapter Plate

Take these steps to install the Cisco RPS Adapter Plate:

- Step 1** Attach the DC power rating label over the ratings on the rear panel of the router (see Figure 8).

Figure 8 Attaching the Cisco 4000 Series DC Power Rating Label

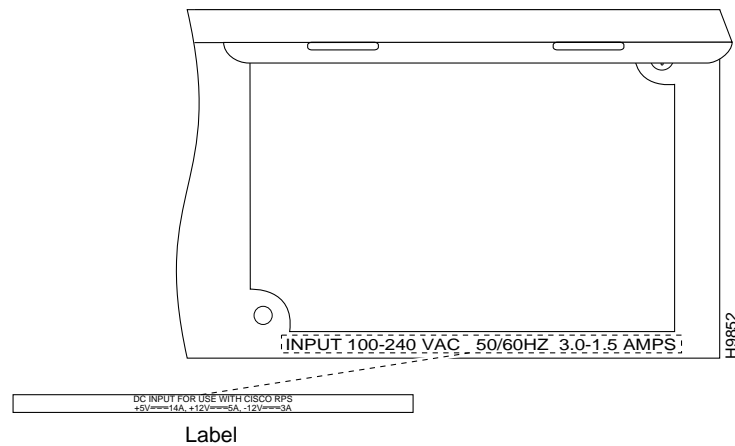

Step 2 Align the Cisco RPS Adapter Plate with the chassis cutout for the power supply. (See Figure 9.)

Figure 9 Installing the Cisco 4000 Series Adapter Plate

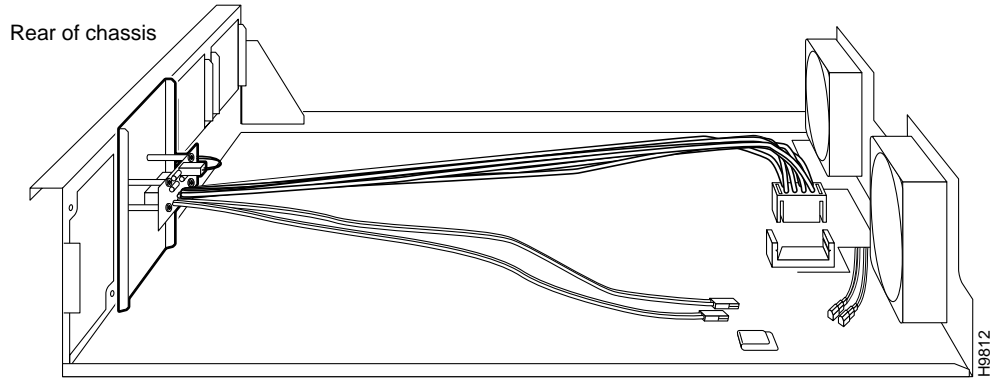

- Step 3** Install the two external rear mounting screws that you removed earlier.
- Step 4** Reconnect the eight-pin connector to the system board. The power connector is keyed so that it cannot be connected to the system board incorrectly. (See Figure 10.)
- Step 5** Reconnect the two small two-pin connectors used to power the fans. (See Figure 10.)

Figure 10 Reconnecting the Connectors

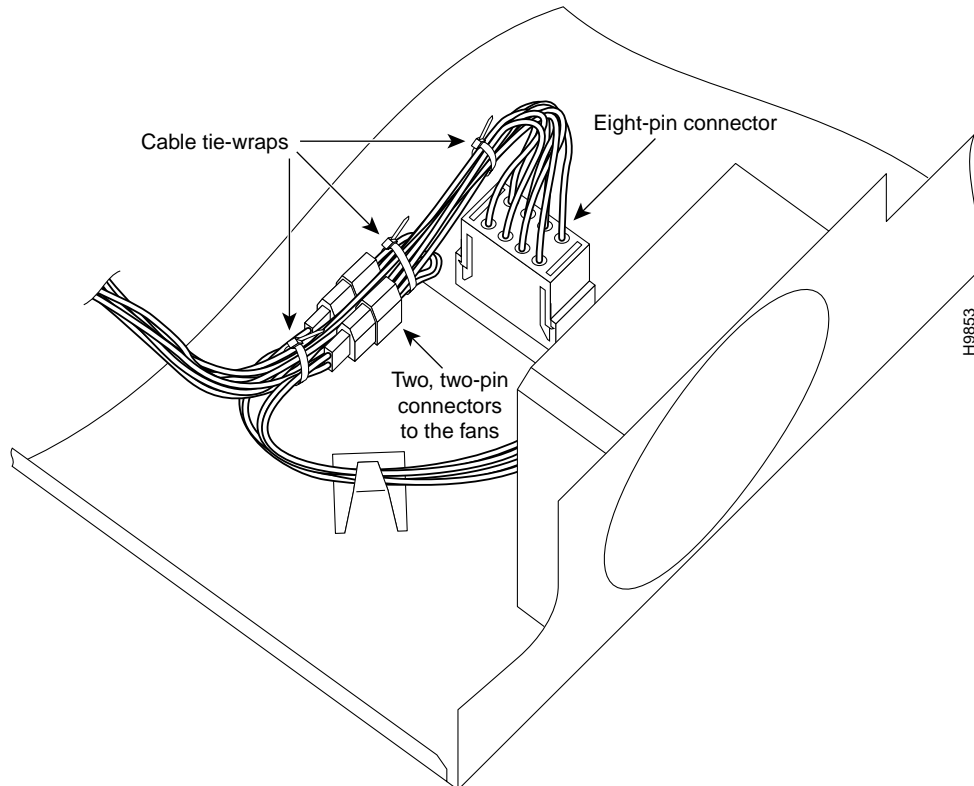

Cisco Connection Online

Cisco Connection Online (CCO) is Cisco Systems' primary, real-time support channel. Maintenance customers and partners can self-register on CCO to obtain additional information and services.

Available 24 hours a day, 7 days a week, CCO provides a wealth of standard and value-added services to Cisco's customers and business partners. CCO services include product information, product documentation, software updates, release notes, technical tips, the Bug Navigator, configuration notes, brochures, descriptions of service offerings, and download access to public and authorized files.

CCO serves a wide variety of users through two interfaces that are updated and enhanced simultaneously: a character-based version and a multimedia version that resides on the World Wide Web (WWW). The character-based CCO supports Zmodem, Kermit, Xmodem, FTP, and Internet e-mail, and it is excellent for quick access to information over lower bandwidths. The WWW version of CCO provides richly formatted documents with photographs, figures, graphics, and video, as well as hyperlinks to related information.

You can access CCO in the following ways:

- WWW: <http://www.cisco.com>
- WWW: <http://www-europe.cisco.com>
- WWW: <http://www-china.cisco.com>
- Telnet: cco.cisco.com
- Modem: From North America, 408 526-8070; from Europe, 33 1 64 46 40 82. Use the following terminal settings: VT100 emulation; databits: 8; parity: none; stop bits: 1; and connection rates up to 28.8 kbps.

For a copy of CCO's Frequently Asked Questions (FAQ), contact cco-help@cisco.com. For additional information, contact cco-team@cisco.com.

Note If you are a network administrator and need personal technical assistance with a Cisco product that is under warranty or covered by a maintenance contract, contact Cisco's Technical Assistance Center (TAC) at 800 553-2447, 408 526-7209, or tac@cisco.com. To obtain general information about Cisco Systems, Cisco products, or upgrades, contact 800 553-6387, 408 526-7208, or cs-rep@cisco.com.

Use this document with the *Cisco RPS Hardware Installation Guide* and *Regulatory Compliance and Safety Information* publications.

AccessPath, AtmDirector, Cache Director System, CD-PAC, Cisco IOS, the Cisco IOS logo, *CiscoLink*, the Cisco Powered Network logo, ClickStart, ControlStream, FastMate, Fast Step, FragmentFree, IGX, JumpStart, LAN²LAN Enterprise, LAN²LAN Remote Office, MICA, NetBeyond, NetFlow, Netsys Technologies, *Packet*, PIX, Point and Click Internetworking, RouteStream, SMARTnet, Speed, StrataSphere, StrataSphere BILLder, StrataSphere Connection Manager, StrataSphere Modeler, StrataSphere Optimizer, Stratm, StreamView, SwitchProbe, *The Cell*, TokenSwitch, TrafficDirector, VirtualStream, VlanDirector, Workgroup Director, Workgroup Stack, and XCI are trademarks; The Network Works. No Excuses. is a service mark; and BPX, Catalyst, Cisco, Cisco Systems, the Cisco Systems logo, CollisionFree, EtherChannel, FastHub, FastLink, FastNIC, FastPacket, FastSwitch, ForeSight, IPX, LightStream, OptiClass, Personal Ethernet, Phase/IP, StrataCom, and StrataView Plus are registered trademarks of Cisco Systems, Inc. in the U.S. and certain other countries. All other trademarks mentioned in this document are the property of their respective owners.

Copyright © 1997, Cisco Systems, Inc.
All rights reserved. Printed in USA.
976R