



Installing AC Power Supplies in Cisco 2691 Routers

Product Numbers: PWR-2691-AC=

This document describes how to replace the AC power supply in a Cisco 2691 router.

This document is intended for the power supply installer, who should be familiar with electronic circuitry and wiring practices and have experience as an electronic or electromechanical technician. Use this document in conjunction with the *Cisco 2600 Series Hardware Installation Guide* and the *Regulatory Compliance and Safety Information* document for your router.

If you have questions or need help, refer to the [“Obtaining Technical Assistance”](#) section on page 19.

This document contains the following sections:

- [Safety Recommendations](#), page 2
- [Overview of Cisco 2691 Power Supplies](#), page 6
- [Required Tools and Equipment](#), page 6
- [Accessing the Power Supply](#), page 7
- [Replacing the Cisco 2691 Power Supply](#), page 8
- [Electrical Connections for Cisco 2691 Routers](#), page 16
- [Troubleshooting](#), page 17
- [Obtaining Documentation](#), page 18
- [Obtaining Technical Assistance](#), page 19



Warning

Only trained and qualified personnel should be allowed to install or replace this equipment. To see translations of the warnings that appear in this publication, refer to the *Regulatory Compliance and Safety Information* document that accompanied this device.



Warning

Before working on a chassis or working near power supplies, unplug the power cord on AC units. To see translations of the warnings that appear in this publication, refer to the *Regulatory Compliance and Safety Information* document that accompanied this device.



Warning

Before working on a system that has an on/off switch, turn OFF the power and unplug the power cord. To see translations of the warnings that appear in this publication, refer to the *Regulatory Compliance and Safety Information* document that accompanied this device.



Warning

Ultimate disposal of this product should be handled according to all national laws and regulations. To see translations of the warnings that appear in this publication, refer to the *Regulatory Compliance and Safety Information* document that accompanied this device.



Caution

To avoid damaging electrostatic discharge (ESD)-sensitive components, ensure that you have discharged all static electricity from your body before opening the chassis. Before performing procedures described in this document, review the next section, "[Safety Recommendations](#)."

Safety Recommendations

Follow these guidelines to ensure general safety:

- Keep the chassis area clear and dust-free during and after installation.
- Place the removed chassis cover in a safe place.
- Keep tools away from walk areas where you or others could fall over them.
- Do not wear loose clothing that may get caught in the chassis. Fasten your tie or scarf and roll up your sleeves.
- Wear safety glasses when working under conditions that may be hazardous to your eyes.
- Do not perform any action that creates a potential hazard to people or makes the equipment unsafe.



Warning

The ISDN connection is regarded as a source of voltage that should be inaccessible to user contact. Do not attempt to tamper with or open any public telephone operator (PTO)-provided equipment or connection hardware. Any hardwired connection (other than by a nonremovable, connect-one-time-only plug) must be made only by PTO staff or suitably trained engineers. To see translations of the warnings that appear in this publication, refer to the *Regulatory Compliance and Safety Information* document that accompanied this device.



Warning

The Ethernet 10BaseT, Token Ring, serial, console, and auxiliary ports contain safety extra-low voltage (SELV) circuits. BRI circuits are treated like telephone-network voltage (TNV) circuits. Avoid connecting SELV circuits to TNV circuits. To see translations of the warnings that appear in this publication, refer to the *Regulatory Compliance and Safety Information* document that accompanied this device.

Safety with Electricity



Warning

Before working on equipment that is connected to power lines, remove jewelry (including rings, necklaces, and watches). Metal objects will heat up when connected to power and ground and can cause serious burns or weld the metal object to the terminals. To see translations of the warnings that appear in this publication, refer to the *Regulatory Compliance and Safety Information* document that accompanied this device.

Follow these guidelines when working on equipment powered by electricity:

- Locate the room's emergency power-off switch. Then, if an electrical accident occurs, you can quickly shut the power off.
- Before working on the system, turn off the power and unplug the power cord.
- Disconnect all power before doing the following:
 - Working on or near power supplies
 - Installing or removing a router chassis or network processor module
 - Performing most hardware upgrades
- Do not work alone if potentially hazardous conditions exist.
- Look carefully for possible hazards in your work area, such as moist floors, ungrounded power extension cables, and missing safety grounds.
- Never assume that power is disconnected from a circuit. Always check.
- If an electrical accident occurs, proceed as follows:
 - Use caution, and do not become a victim yourself.
 - Turn off power to the system.
 - If possible, send another person to get medical aid. Otherwise, determine the condition of the victim and then call for help.
 - Determine if the person needs rescue breathing or external cardiac compressions; then take appropriate action.

Preventing Electrostatic Discharge Damage

Electrostatic discharge (ESD) can damage equipment and impair electrical circuitry. It occurs when electronic printed circuit cards are improperly handled and can result in complete or intermittent failures. Always follow ESD prevention procedures when removing and replacing cards. Ensure that the router chassis is electrically connected to earth ground. Wear an ESD-preventive wrist strap, ensuring that it makes good skin contact. Connect the clip to an unpainted surface of the chassis frame to safely channel unwanted ESD voltages to ground. To properly guard against ESD damage and shocks, the wrist strap and cord must operate effectively. If no wrist strap is available, ground yourself by touching the metal part of the chassis.



Caution

For safety, periodically check the resistance value of the antistatic strap, which should be between 1 and 10 megohms (Mohms).

Safety Regulations



Warning

Means *danger*. You are in a situation that could cause bodily injury. Before you work on any equipment, be aware of the hazards involved with electrical circuitry and be familiar with standard practices for preventing accidents. To see translations of the warnings that appear in this publication, refer to the *Regulatory Compliance and Safety Information* document that accompanied this device.

Waarschuwing

Dit waarschuwingssymbool betekent gevaar. U verkeert in een situatie die lichamelijk letsel kan veroorzaken. Voordat u aan enige apparatuur gaat werken, dient u zich bewust te zijn van de bij elektrische schakelingen betrokken risico's en dient u op de hoogte te zijn van standaard maatregelen om ongelukken te voorkomen. Voor vertalingen van de waarschuwingen die in deze publicatie verschijnen, kunt u het document *Regulatory Compliance and Safety Information* (Informatie over naleving van veiligheids- en andere voorschriften) raadplegen dat bij dit toestel is ingesloten.

Varoitus

Tämä varoitusmerkki merkitsee vaaraa. Olet tilanteessa, joka voi johtaa ruumiinvammaan. Ennen kuin työskentelet minkään laitteiston parissa, ota selvää sähkökytkentöihin liittyvistä vaaroista ja tavanomaisista onnettomuuksien ehkäisykeinoista. Tässä julkaisussa esiintyvien varoitusten käännökset löydät laitteen mukana olevasta *Regulatory Compliance and Safety Information* -kirjasesta (määräysten noudattaminen ja tietoa turvallisuudesta).

Attention

Ce symbole d'avertissement indique un danger. Vous vous trouvez dans une situation pouvant causer des blessures ou des dommages corporels. Avant de travailler sur un équipement, soyez conscient des dangers posés par les circuits électriques et familiarisez-vous avec les procédures couramment utilisées pour éviter les accidents. Pour prendre connaissance des traductions d'avertissements figurant dans cette publication, consultez le document *Regulatory Compliance and Safety Information* (Conformité aux règlements et consignes de sécurité) qui accompagne cet appareil.

Warnung

Dieses Warnsymbol bedeutet Gefahr. Sie befinden sich in einer Situation, die zu einer Körperverletzung führen könnte. Bevor Sie mit der Arbeit an irgendeinem Gerät beginnen, seien Sie sich der mit elektrischen Stromkreisen verbundenen Gefahren und der Standardpraktiken zur Vermeidung von Unfällen bewußt. Übersetzungen der in dieser Veröffentlichung enthaltenen Warnhinweise finden Sie im Dokument *Regulatory Compliance and Safety Information* (Informationen zu behördlichen Vorschriften und Sicherheit), das zusammen mit diesem Gerät geliefert wurde.

Avvertenza

Questo simbolo di avvertenza indica un pericolo. La situazione potrebbe causare infortuni alle persone. Prima di lavorare su qualsiasi apparecchiatura, occorre conoscere i pericoli relativi ai circuiti elettrici ed essere al corrente delle pratiche standard per la prevenzione di incidenti. La traduzione delle avvertenze riportate in questa pubblicazione si trova nel documento *Regulatory Compliance and Safety Information* (Conformità alle norme e informazioni sulla sicurezza) che accompagna questo dispositivo.

Advarsel	Dette varselsymbolet betyr fare. Du befinner deg i en situasjon som kan føre til personskade. Før du utfører arbeid på utstyr, må du være oppmerksom på de faremomentene som elektriske kretser innebærer, samt gjøre deg kjent med vanlig praksis når det gjelder å unngå ulykker. Hvis du vil se oversettelser av de advarslene som finnes i denne publikasjonen, kan du se i dokumentet <i>Regulatory Compliance and Safety Information</i> (Overholdelse av forskrifter og sikkerhetsinformasjon) som ble levert med denne enheten.
Aviso	Este símbolo de aviso indica perigo. Encontra-se numa situação que lhe poderá causar danos físicos. Antes de começar a trabalhar com qualquer equipamento, familiarize-se com os perigos relacionados com circuitos eléctricos, e com quaisquer práticas comuns que possam prevenir possíveis acidentes. Para ver as traduções dos avisos que constam desta publicação, consulte o documento <i>Regulatory Compliance and Safety Information</i> (Informação de Segurança e Disposições Reguladoras) que acompanha este dispositivo.
¡Advertencia!	Este símbolo de aviso significa peligro. Existe riesgo para su integridad física. Antes de manipular cualquier equipo, considerar los riesgos que entraña la corriente eléctrica y familiarizarse con los procedimientos estándar de prevención de accidentes. Para ver una traducción de las advertencias que aparecen en esta publicación, consultar el documento titulado <i>Regulatory Compliance and Safety Information</i> (Información sobre seguridad y conformidad con las disposiciones reglamentarias) que se acompaña con este dispositivo.
Varning!	Denna varningssymbol signalerar fara. Du befinner dig i en situation som kan leda till personskada. Innan du utför arbete på någon utrustning måste du vara medveten om farorna med elkretsar och känna till vanligt förfarande för att förebygga skador. Se förklaringar av de varningar som förkommer i denna publikation i dokumentet <i>Regulatory Compliance and Safety Information</i> (Efterrättelse av föreskrifter och säkerhetsinformation), vilket medföljer denna anordning.

FCC Class A Compliance

The equipment described in this document generates and may radiate radio-frequency energy. If it is not installed in accordance with Cisco installation instructions, it may cause interference with radio and television reception. This equipment has been tested and found to comply with the limits for a Class A digital device in accordance with the specifications in part 15 of the FCC rules. These specifications are designed to provide reasonable protection against such interference in a residential installation. However, there is no guarantee that interference will not occur in a particular installation.

You can determine whether your equipment is causing interference by turning it off. If the interference stops, it was probably caused by the Cisco equipment or one of its peripheral devices. If the equipment causes interference to radio or television reception, try to correct the interference by using one or more of the following measures:

- Turn the television or radio antenna until the interference stops.
- Move the equipment to one side or the other of the television or radio.
- Move the equipment farther away from the television or radio.
- Plug the equipment into an outlet that is on a different circuit from the television or radio. (That is, make certain that the equipment and the television or radio are on circuits controlled by different circuit breakers or fuses.)

Modifications to this product not authorized by Cisco Systems, Inc. could void the FCC approval and negate your authority to operate the product.

Required Tools and Equipment

Installation might require some tools and equipment that are not provided as standard equipment with the router. Following are the tools and parts required for a typical router installation:

- Number 2 Phillips screwdriver
- ESD-preventive wrist strap

Overview of Cisco 2691 Power Supplies

Figure 1 shows the AC power supply for the Cisco 2691 router.

Figure 2 shows the location of the power supply in the Cisco 2691 router.

Figure 1 Cisco 2691 AC Power Supply

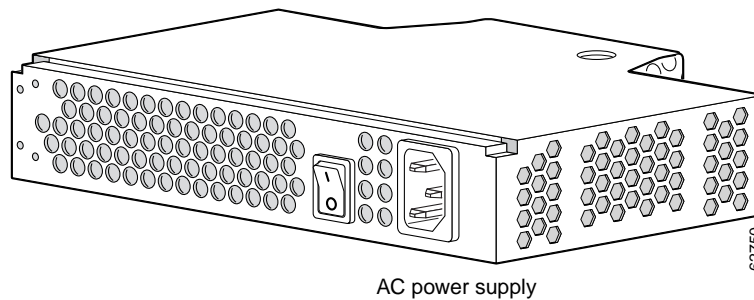
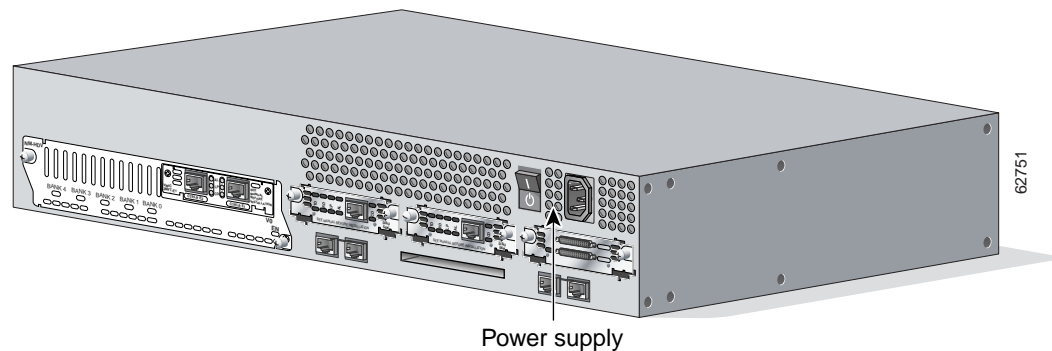

Figure 2 Power Supply Location in the Cisco 2691 Router



Power Requirements for the Cisco 2691 Router

The following power requirements apply to the Cisco 2691 router:

Type	Cisco 2691
Input voltage, AC power supply	100 to 120, 120V VAC 200 to 240, 230V VAC 47 to 63 Hz
Frequency	0.93 min. @ 120VAC 60Hz
Current emissions (AC)	when loaded at 50% or higher
Minimum efficiency	60% @ 85V, 64% @ 100VAC to 264VAC
Line surge (120 VAC)	160VAC - 1/2 cycle, 140VAC - 5 cycles
Line surge (2400 VAC)	320VAC - 1/2 cycle, 280VAC - 5 cycles

Accessing the Power Supply

To access power supplies on the Cisco 2691 router, remove the router cover as described in the [“Removing the Router Cover”](#) section on page 8.



Warning

Before working on a chassis or working near power supplies, unplug the power cord on AC units. To see translations of the warnings that appear in this publication, refer to the *Regulatory Compliance and Safety Information* document that accompanied this device.



Warning

Do not touch the power supply when the power cord is connected. For systems with a power switch, line voltages are present within the power supply even when the power switch is off and the power cord is connected. For systems without a power switch, line voltages are present within the power supply when the power cord is connected. To see translations of the warnings that appear in this publication, refer to the *Regulatory Compliance and Safety Information* document that accompanied this device.



Warning

Do not work on the system or connect or disconnect cables during periods of lightning activity. To see translations of the warnings that appear in this publication, refer to the *Regulatory Compliance and Safety Information* document that accompanied this device.



Warning

Before opening the chassis, disconnect the telephone-network cables to avoid contact with telephone-network voltages. To see translations of the warnings that appear in this publication, refer to the *Regulatory Compliance and Safety Information* document that accompanied this device.

**Warning**

Network hazardous voltages are present in the BRI cable. If you detach the BRI cable, detach the end away from the router first to avoid possible electric shock. Network hazardous voltages also are present on the system card in the area of the BRI port (RJ-45 connector), regardless of when power is turned off. To see translations of the warnings that appear in this publication, refer to the *Regulatory Compliance and Safety Information* document that accompanied this device.

Replacing the Cisco 2691 Power Supply

The power supply and cabling for the Cisco 2691 router is contained inside the chassis. To replace the power supply, complete these procedures:

- [Removing the Router Cover, page 8](#)
- [Removing the Cisco 2691 Power Supply, page 9](#)
- [Installing the Cisco 2691 Power Supply, page 14](#)
- [Replacing the Router Cover, page 14](#)

Removing the Router Cover

To gain access to the Cisco 2691 power supply, you must first remove the chassis cover:

-
- Step 1** Turn off power to the router.
 - Step 2** Remove all network interface cables from the rear panel.
 - Step 3** If you have an AC-powered router, remove the power cord.

**Warning**

When installing the unit, always make the ground connection first and disconnect it last. To see translations of the warnings that appear in this publication, refer to the *Regulatory Compliance and Safety Information* document that accompanied this device.

- Step 4** Place the router so the rear panel is closest to you. Remove the five screws located on top of the cover. Set the screws aside in a safe place.
- Step 5** Lift the front edge of the cover. (See number 1 in [Figure 3](#).)
- Step 6** Slide the cover toward the right until the metal tabs on the rear edge separate from the chassis bottom. (See number 2 in [Figure 3](#).)

Figure 3 Removing the Cisco 2691 Cover

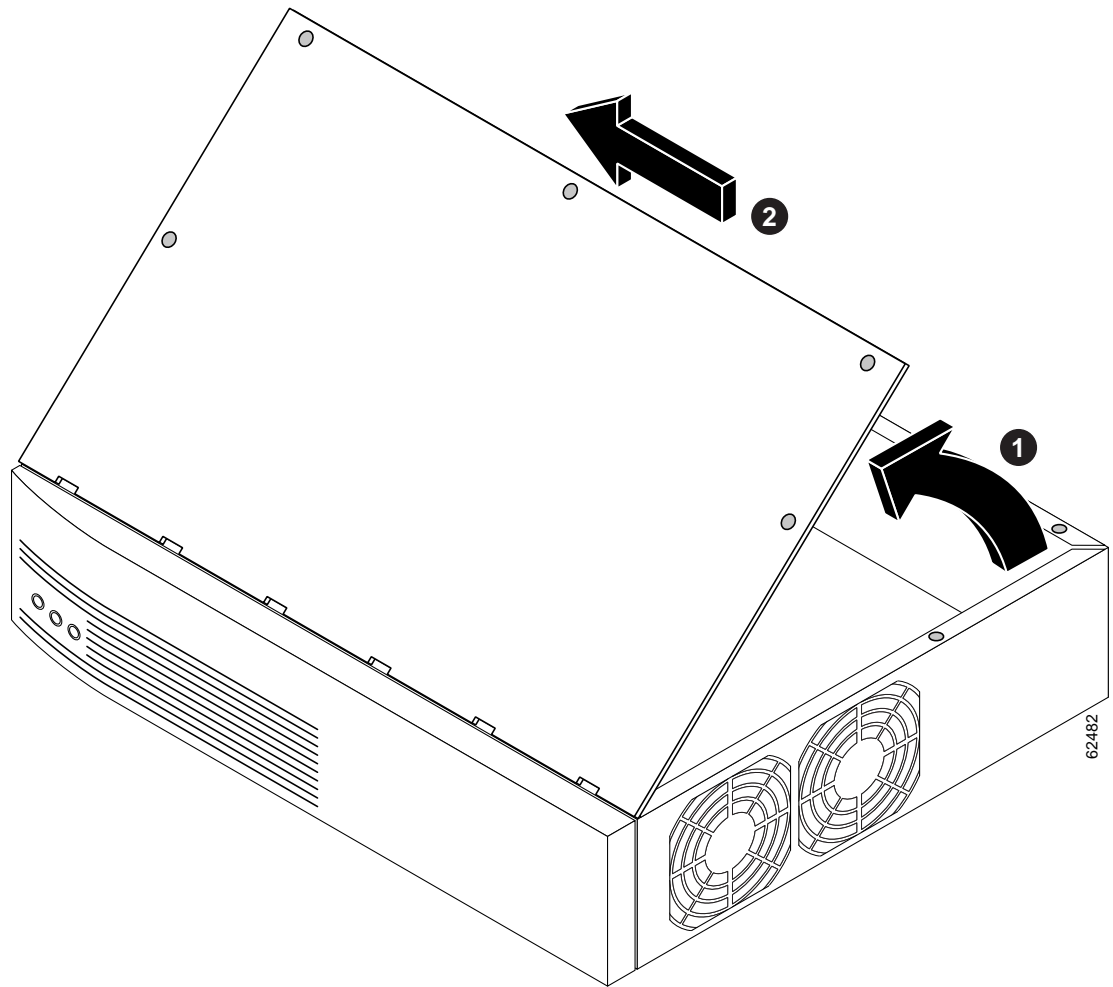

- Step 7** Lift the cover completely off and set it aside.
When you are ready to replace the cover, see the [“Replacing the Router Cover”](#) section on page 14.

Removing the Cisco 2691 Power Supply

After you remove the cover from the chassis, follow this procedure to remove the power supply:

- Step 1** Find the Compact Flash memory card located on the side wall of the chassis. (See [Figure 4](#).)

Figure 4 Cisco 2691 Compact Flash

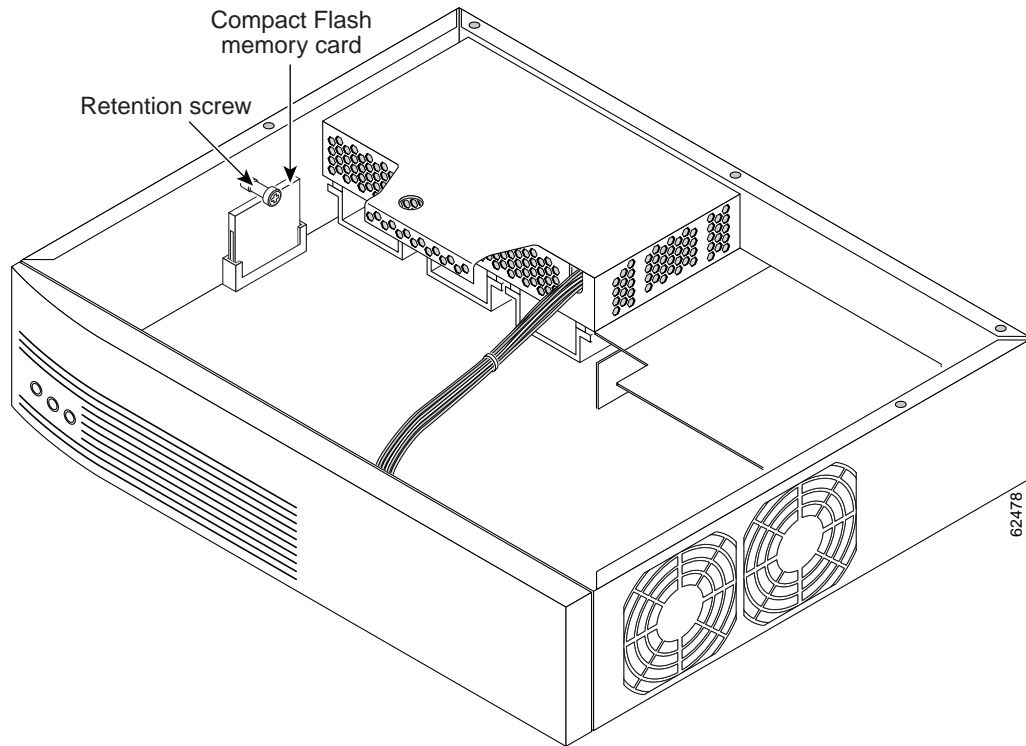

- Step 2 Remove the Compact Flash memory retention screw and set it aside. (See [Figure 4](#).)
- Step 3 Lift the Compact Flash memory card up and away from the Compact Flash receptacle and set it aside. (See [Figure 4](#).)
- Step 4 Find the large power connector on the motherboard and remove it. (See [Figure 5](#).)



Note On a Cisco 2691 router, you can simply lift the connector away from the receptacle. (See [Figure 5](#).)

Figure 5 Removing the Cisco 2691 Power Connector

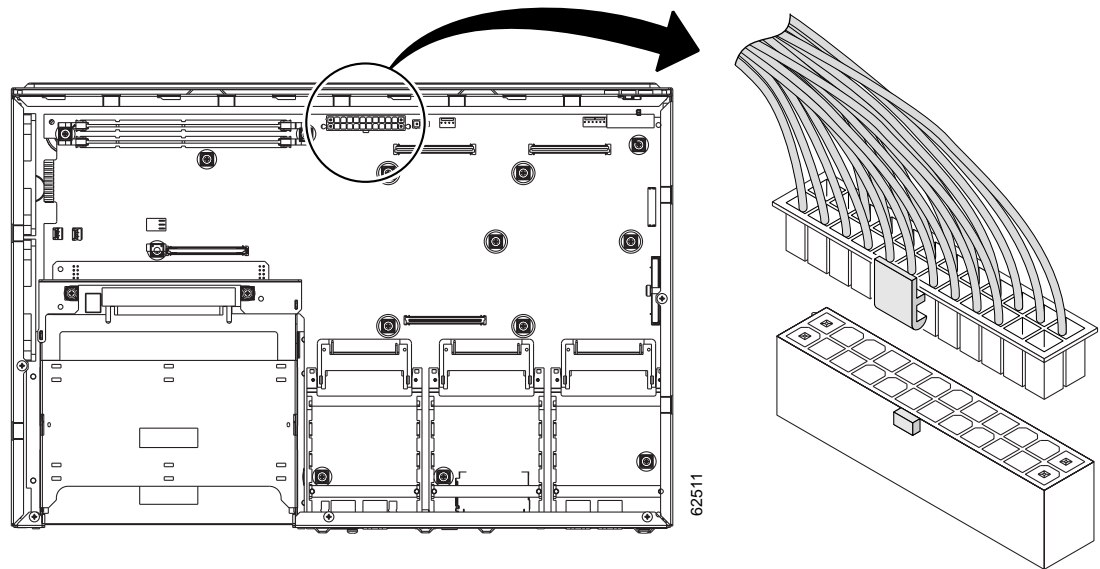

- Step 5** The Cisco 2691 power supply is held in the chassis by three external mounting screws at the rear of the router. (See [Figure 6](#).) Remove the screws and set them aside.

Figure 6 Cisco 2691 Power Supply Mounting Screws

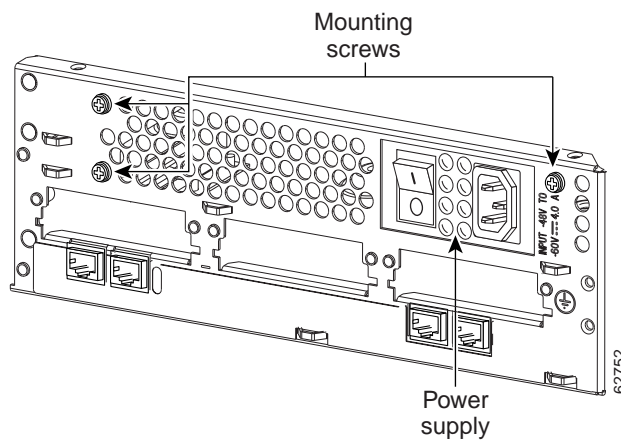

- Step 6** Slide the power supply back slightly in the chassis. This disengages the hooks built into the chassis that help secure the power supply. (See [Figure 7](#) and [Figure 8](#).)

Figure 7 Cisco 2691 Power Supply Mounting Hinge (Right)

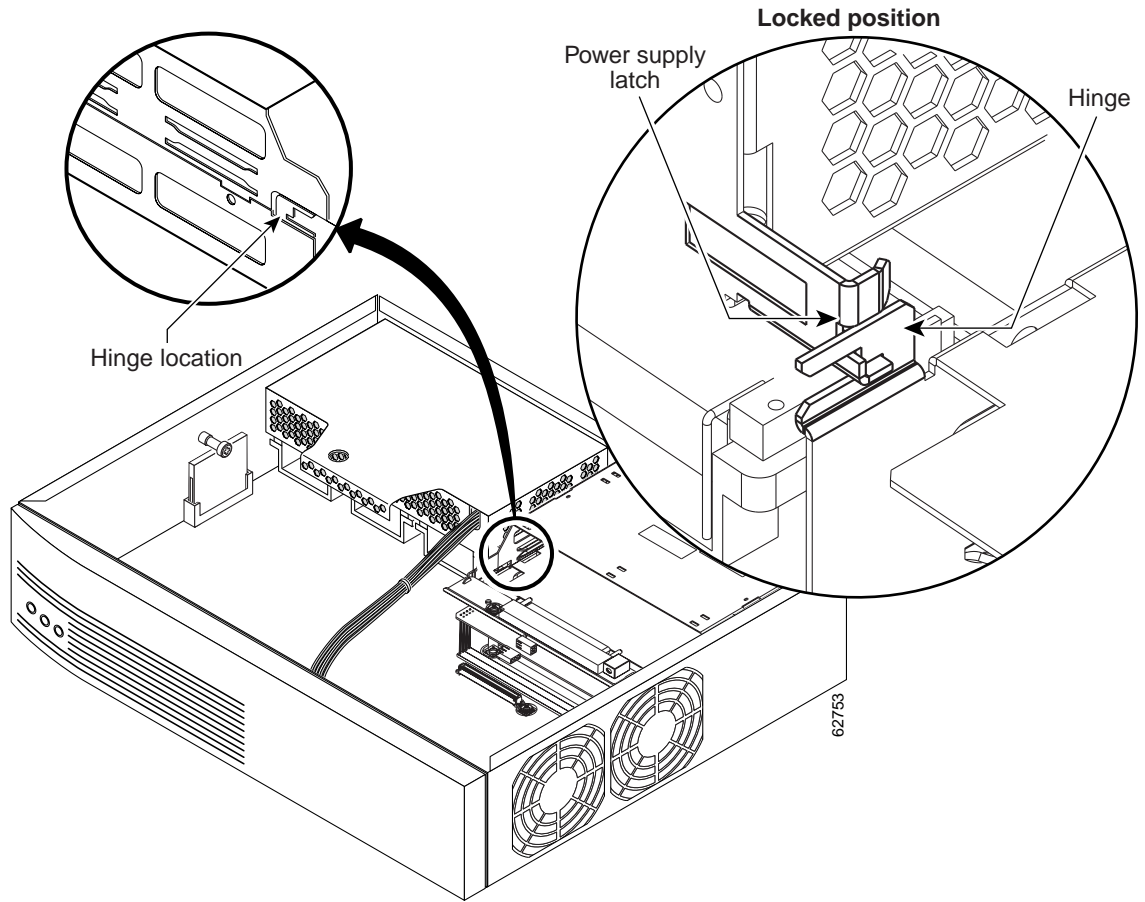
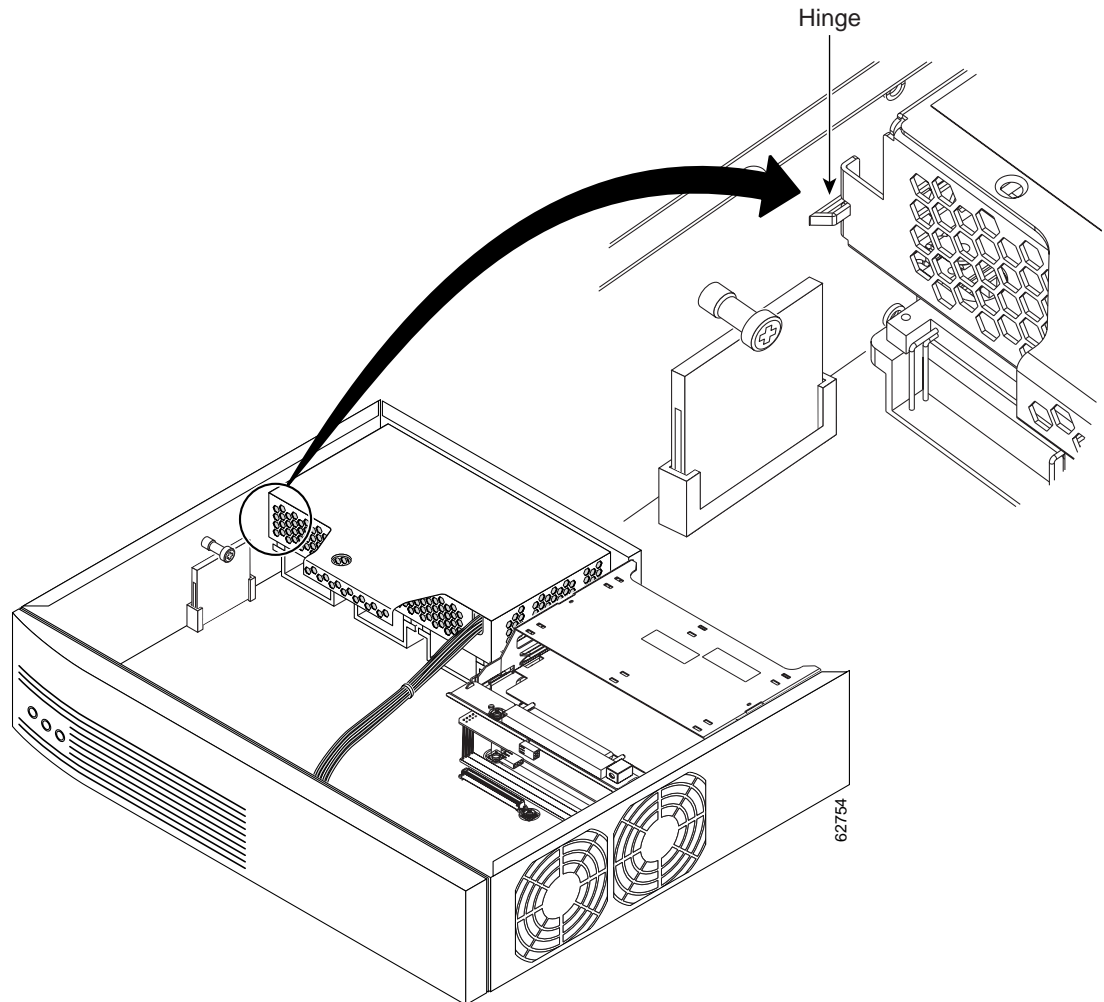
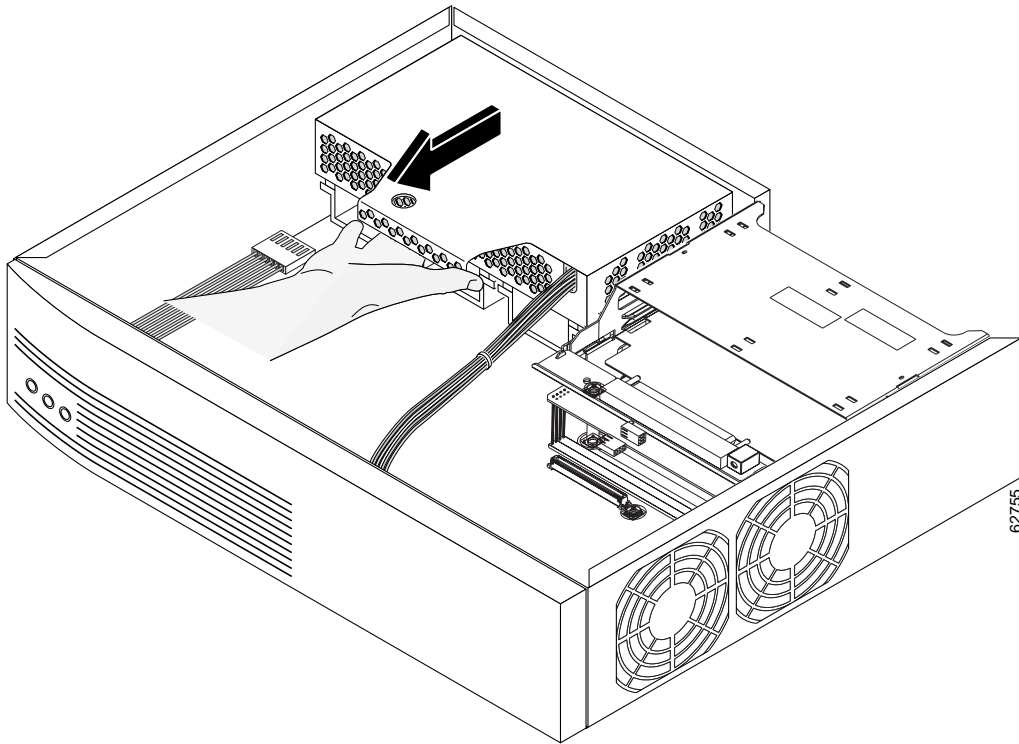

Figure 8 Cisco 2691 Power Supply Mounting Hinge (Left)



Step 7 Pull the power supply back and lift the power supply out of the chassis. (See [Figure 9](#).)

Figure 9 Cisco 2691 Power Supply Removal



Installing the Cisco 2691 Power Supply

Follow these steps to install a power supply in the chassis:

-
- Step 1 Place the power supply in the chassis, with the power supply rear panel slightly separated from the chassis rear panel. This position allows the hooks in the chassis to engage the cutouts in the bottom of the power supply. (See [Figure 7](#) and [Figure 8](#).)
 - Step 2 Slide the power supply toward the rear of the chassis, engaging the hooks in the chassis.
 - Step 3 Replace the three external rear mounting screws. (See [Figure 6](#).)
 - Step 4 Insert the large power connector into the receptacle on the motherboard. (See [Figure 5](#).)
 - Step 5 Reinsert the Compact Flash memory card in the receptacle and screw in the Compact Flash memory retention screw.
-

Replacing the Router Cover

After you finish replacing the power supply, follow these steps to replace the cover:

-
- Step 1 Place the chassis bottom so the front panel is closest to you.

- Step 2** Hold the cover so the tabs at the rear of the cover are aligned with the chassis bottom.
- Step 3** Push the cover toward the rear, making sure that the cover tabs fit under the chassis back panel, and the back panel tabs fit under the cover.
- Step 4** Slide the cover slightly to the left to lock the cover into position (number 1 in [Figure 10](#)).

Figure 10 Replacing the Cisco 2691 Router Cover

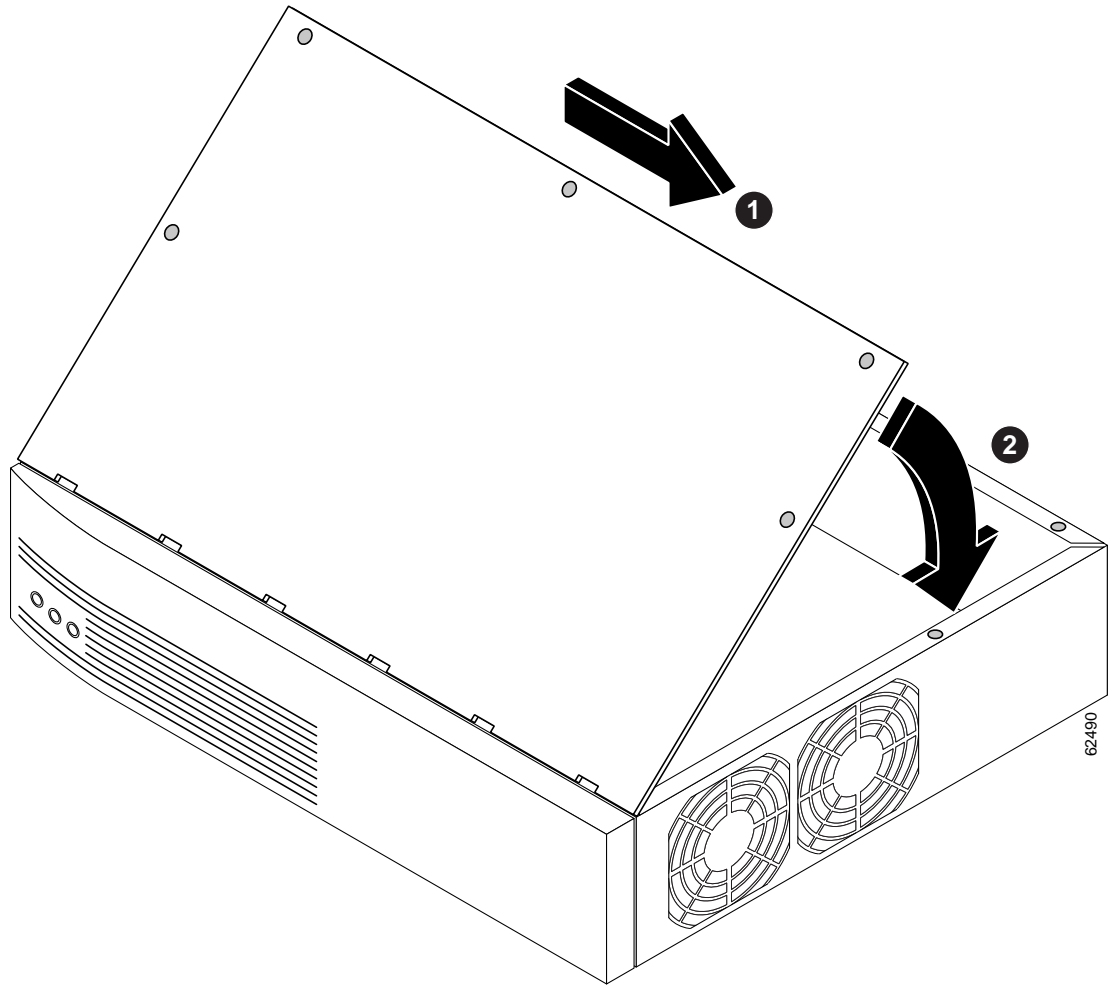

- Step 5** Lower the front of the cover onto the chassis (number 2 in [Figure 10](#)).
- Step 6** Fasten the cover with the five screws you set aside earlier.
- Step 7** Reinstall the chassis on a rack.
- Step 8** Reinstall network interface cables.
- Step 9** Proceed to the [“Electrical Connections for Cisco 2691 Routers”](#) section on page 16.

Electrical Connections for Cisco 2691 Routers

This section explains how to connect the AC power to Cisco 2691 routers.

 Warning

This unit is intended for installation in restricted access areas. A restricted access area is where access can only be gained by service personnel through the use of a special tool, lock and key, or other means of security, and is controlled by the authority responsible for the location. To see translations of the warnings that appear in this publication, refer to the *Regulatory Compliance and Safety Information* document that accompanied this device.



Note

The installation must comply with the 1996 National Electric Code (NEC) and other applicable codes.

 Warning

Use copper conductors only.

- Step 1 Crimp a size AWG 6 (minimum 13 mm²) ground wire in the new equipment building system (NEBS) ground lug.
- Step 2 Attach the ground lug to the Cisco 2691 chassis, using the supplied screws as shown in [Figure 11](#).
- Step 3 Connect the other end of the ground wire to a suitable grounding point at your site.

Figure 11 NEBS-Compliant Ground Connection on the Cisco 2691 Router

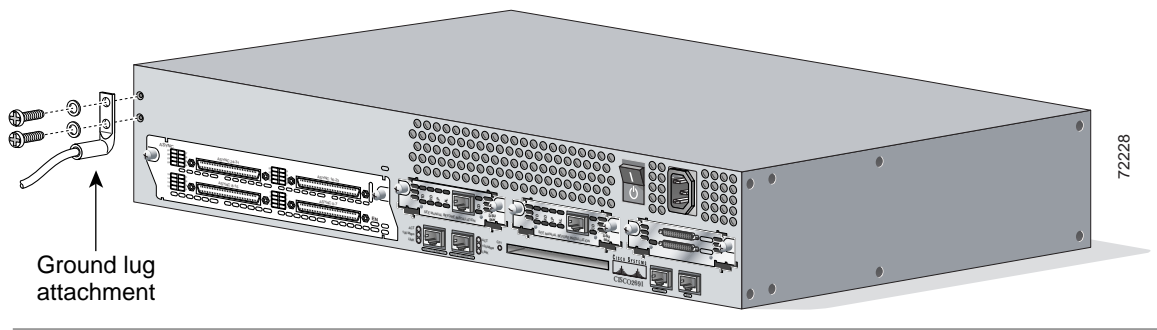

Powering On the Router

 Warning

The plug-socket combination must be accessible at all times because it serves as the main disconnecting device. To see translations of the warnings that appear in this publication, refer to the *Regulatory Compliance and Safety Information* document that accompanied this device.

**Caution**

Never operate the router unless the unit is completely closed, to ensure adequate cooling.

Take the following steps to power on the router:

Step 1

For routers with AC input, plug the router's power cord into a three-terminal, single-phase power source that provides power within the acceptable range.

**Warning**

This product relies on the building's installation or power supply for short circuit (overcurrent) protection. Ensure that a Listed and Certified fuse or circuit breaker no larger than 60 VDC, 15A is used on all current-carrying conductors. To see translations of the warnings that appear in this publication, refer to the *Regulatory Compliance and Safety Information* document that accompanied this device.

Step 2

Power on the router. The LED labeled SYSTEM on the front panel should come on.

If you encounter problems when you power on the router, see the "[Troubleshooting](#)" section that follows.

Troubleshooting

Check the following items to help isolate problems with the power supply installation:

- With the power switch on, is the power LED on the front panel on?
 - If not, check the AC input, AC source, router circuit breaker, and the power supply cable (AC).
 - Check the power supply connection to the motherboard.
 - If the power LED is still off, the problem might be a power supply failure.
- Does the router shut down after being on a short time?
 - Check the fans. If the fans are not working, the router will overheat and shut itself down.
 - If the fans are not working, check the power supply connections to the fans.
 - Ensure that the chassis intake and exhaust vents are clear.
 - Check the environmental site requirements in your router installation and configuration guide.

Obtaining Documentation

The following sections explain how to obtain documentation from Cisco Systems.

World Wide Web

You can access the most current Cisco documentation on the World Wide Web at the following URL:

<http://www.cisco.com>

Translated documentation is available at the following URL:

http://www.cisco.com/public/countries_languages.shtml

Documentation CD-ROM

Cisco documentation and additional literature are available in a Cisco Documentation CD-ROM package, which is shipped with your product. The Documentation CD-ROM is updated monthly and may be more current than printed documentation. The CD-ROM package is available as a single unit or through an annual subscription.

Ordering Documentation

Cisco documentation is available in the following ways:

- Registered Cisco Direct Customers can order Cisco product documentation from the Networking Products MarketPlace:
http://www.cisco.com/cgi-bin/order_root.pl
- Registered Cisco.com users can order the Documentation CD-ROM through the online Subscription Store:
<http://www.cisco.com/go/subscription>
- Nonregistered Cisco.com users can order documentation through a local account representative by calling Cisco corporate headquarters (California, USA) at 408 526-7208 or, elsewhere in North America, by calling 800 553-NETS (6387).

Documentation Feedback

If you are reading Cisco product documentation on Cisco.com, you can submit technical comments electronically. Click **Leave Feedback** at the bottom of the Cisco Documentation home page. After you complete the form, print it out and fax it to Cisco at 408 527-0730.

You can e-mail your comments to bug-doc@cisco.com.

To submit your comments by mail, use the response card behind the front cover of your document, or write to the following address:

Cisco Systems
Attn: Document Resource Connection
170 West Tasman Drive
San Jose, CA 95134-9883

We appreciate your comments.

Obtaining Technical Assistance

Cisco provides Cisco.com as a starting point for all technical assistance. Customers and partners can obtain documentation, troubleshooting tips, and sample configurations from online tools by using the Cisco Technical Assistance Center (TAC) Web Site. Cisco.com registered users have complete access to the technical support resources on the Cisco TAC Web Site.

Cisco.com

Cisco.com is the foundation of a suite of interactive, networked services that provides immediate, open access to Cisco information, networking solutions, services, programs, and resources at any time, from anywhere in the world.

Cisco.com is a highly integrated Internet application and a powerful, easy-to-use tool that provides a broad range of features and services to help you to

- Streamline business processes and improve productivity
- Resolve technical issues with online support
- Download and test software packages
- Order Cisco learning materials and merchandise
- Register for online skill assessment, training, and certification programs

You can self-register on Cisco.com to obtain customized information and service. To access Cisco.com, go to the following URL:

<http://www.cisco.com>

Technical Assistance Center

The Cisco TAC is available to all customers who need technical assistance with a Cisco product, technology, or solution. Two types of support are available through the Cisco TAC: the Cisco TAC Web Site and the Cisco TAC Escalation Center.

Inquiries to Cisco TAC are categorized according to the urgency of the issue:

- Priority level 4 (P4)—You need information or assistance concerning Cisco product capabilities, product installation, or basic product configuration.
- Priority level 3 (P3)—Your network performance is degraded. Network functionality is noticeably impaired, but most business operations continue.
- Priority level 2 (P2)—Your production network is severely degraded, affecting significant aspects of business operations. No workaround is available.
- Priority level 1 (P1)—Your production network is down, and a critical impact to business operations will occur if service is not restored quickly. No workaround is available.

Which Cisco TAC resource you choose is based on the priority of the problem and the conditions of service contracts, when applicable.

Cisco TAC Web Site

The Cisco TAC Web Site allows you to resolve P3 and P4 issues yourself, saving both cost and time. The site provides around-the-clock access to online tools, knowledge bases, and software. To access the Cisco TAC Web Site, go to the following URL:

<http://www.cisco.com/tac>

All customers, partners, and resellers who have a valid Cisco services contract have complete access to the technical support resources on the Cisco TAC Web Site. The Cisco TAC Web Site requires a Cisco.com login ID and password. If you have a valid service contract but do not have a login ID or password, go to the following URL to register:

<http://www.cisco.com/register>

If you cannot resolve your technical issues by using the Cisco TAC Web Site, and you are a Cisco.com registered user, you can open a case online by using the TAC Case Open tool at the following URL:

<http://www.cisco.com/tac/caseopen>

If you have Internet access, it is recommended that you open P3 and P4 cases through the Cisco TAC Web Site.

Cisco TAC Escalation Center

The Cisco TAC Escalation Center addresses issues that are classified as priority level 1 or priority level 2; these classifications are assigned when severe network degradation significantly impacts business operations. When you contact the TAC Escalation Center with a P1 or P2 problem, a Cisco TAC engineer will automatically open a case.

To obtain a directory of toll-free Cisco TAC telephone numbers for your country, go to the following URL:

<http://www.cisco.com/warp/public/687/Directory/DirTAC.shtml>

Before calling, please check with your network operations center to determine the level of Cisco support services to which your company is entitled; for example, SMARTnet, SMARTnet Onsite, or Network Supported Accounts (NSA). In addition, please have available your service agreement number and your product serial number.

CCIP, the Cisco *Powered* Network mark, the Cisco Systems Verified logo, Cisco Unity, Fast Step, Follow Me Browsing, FormShare, Internet Quotient, iQ Breakthrough, iQ Expertise, iQ FastTrack, the iQ Logo, iQ Net Readiness Scorecard, Networking Academy, ScriptShare, SMARTnet, TransPath, and Voice LAN are trademarks of Cisco Systems, Inc.; Changing the Way We Work, Live, Play, and Learn, Discover All That's Possible, The Fastest Way to Increase Your Internet Quotient, and iQuick Study are service marks of Cisco Systems, Inc.; and Aironet, ASIST, BPX, Catalyst, CCDA, CCDP, CCIE, CCNA, CCNP, Cisco, the Cisco Certified Internetwork Expert logo, Cisco IOS, the Cisco IOS logo, Cisco Press, Cisco Systems, Cisco Systems Capital, the Cisco Systems logo, Empowering the Internet Generation, Enterprise/Solver, EtherChannel, EtherSwitch, GigaStack, IOS, IP/TV, LightStream, MICA, the Networkers logo, Network Registrar, *Packet*, PIX, Post-Routing, Pre-Routing, RateMUX, Registrar, SlideCast, StrataView Plus, Stratm, SwitchProbe, TeleRouter, and VCO are registered trademarks of Cisco Systems, Inc. and/or its affiliates in the U.S. and certain other countries.

All other trademarks mentioned in this document or Web site are the property of their respective owners. The use of the word partner does not imply a partnership relationship between Cisco and any other company. (0201R)

Copyright © 2002, Cisco Systems, Inc.
All rights reserved.